



RWF40... complete with housing

Compact Universal Controllers

RWF40...

The RWF40... is a universal digital boiler temperature / pressure controller with functions designed specifically for the control of heat generating plant.

The RWF40... and this Data Sheet are intended for use by OEMs which integrate the controller in their products!

Mechanical design

The controller is supplied complete with housing for flush panel mounting. The RWF40... is matched to the controlled variable and the required setpoint range by making parameter settings. The control parameters can be set and optimized while the burner is running. All settings are made with 4 buttons located on the unit front and are directly displayed.

LEDs on the front indicate the following operating states:

- Control ON / OFF
- Positioning pulses ON or OFF for driving the burner's air damper when using modulating burner control, or stage I / stage II when using 2-stage burner control
- «2-stage» operating mode
- Position of the configurable contact «K6»
- Manual control ON / OFF

During operation, the digital display above the LEDs shows the setpoint (green), the actual value (red) and – when making parameter settings – the relevant parameters.

Warning notes



To avoid injury to persons, damage to property or the environment, the following warning notes must be observed!

Do not open, interfere with or modify the controller!

- All activities (mounting, installation and service work, etc.) must be performed by qualified staff
- When selecting the cables, when making the installation and the electrical connections, observe the regulations of VDE 0100 «Erection of power installations with rated voltages below AC 1000 V» and the relevant national regulations
- Provide double-pole isolation of the controller from the mains supply if there is a risk of touching live parts while work is carried out
- Each time work has been carried out (mounting, installation, service work, etc.), check to ensure that wiring is in an orderly state
- Fall or shock can adversely affect the safety functions. Such units must not be put into operation, even if they do not exhibit any damage

Mounting notes

- Ensure that the relevant national safety regulations are complied with

Installation notes

- Please observe the notes given in the user documentation B7865

Standards and certificates



Conformity to EEC directives

- Electromagnetic compatibility EMC (immunity) 2004/108/EC
- Electromagnetic compatibility EMC NE21, EN 50081 part 1 and EN 50082 part 2
- NAMUR recommendation
- Low-voltage directive 2006/95/EC



ISO 9001: 2000
Cert. 00739



ISO 14001: 2004
Cert. 38233



Service notes

- For service purposes, the controller can be removed from its housing with no need for tools
- The electrical connections are made via the screw terminals located at the rear of the housing

Disposal notes



The unit contains electrical and electronic components and must not be disposed of together with household waste.
Local and currently valid legislation must be observed.

Type summary

Controller with <ul style="list-style-type: none">- 3-position output- housing- fixing material and seal	RWF40.000A97
Controller with <ul style="list-style-type: none">- 3-position output- analog output- housing- fixing material and seal	RWF40.001A97
Controller with <ul style="list-style-type: none">- 3-position output- analog output- RS-485 port- housing- fixing material and seal	RWF40.002B97
Packaging variants (20 pieces, without documentation)	RWF40.010A97 RWF40.011A97 RWF40.012B97

Accessories



Adapter frame for replacing the RWF32...

ARG40



Bracket

For mounting the RWF40... on 35 mm DIN rails to DIN 46277

ARG41



Dummy cover

For covering a panel cutout for the RWF40...

AVA10.200/109



Demo case

For demonstrating the functions of the RWF40... controller

KF8892

Technical data

General controller data	Mains voltage	AC 110...240 V +10% / -10%
	Mains frequency	48...63 Hz
	Safety class	II to DIN 0631
	Mounting position	Optional
	Terminals for	2 x 1.5 mm ² or 1 x 2.5 mm ²
	Power consumption	Max. 10 VA
	Safety extra low-voltage	DC 24 V
	Perm. contact rating of the control outputs (relays «K1...K3»)	
	- Up to 2 x 10 ⁵ switching cycles	2 A / AC 24...240 V
	- Up to 10 ⁷ switching cycles	0.1 A / AC 24...240 V
	Weight complete with housing	Approx. 760 g
	Recommended actuator running time	15...60 s
	Degree of protection of housing	
	- Front	IP65, EN 60529
	- Base	IP20, EN 60529
	Immunity	Industry, to DIN EN 61326-1
	Emitted interference	Class B (small businesses, households) to DIN EN 61326-1
Environmental conditions	Storage	
	Temperature range	-20...+60°C
	Humidity	<75% r.h.
	Transport	
	Temperature range	-40...+70°C
	Humidity	<75% r.h.
Operation		
	Temperature range	-20...+50°C
Humidity	<75% r.h.	



Condensation, formation of ice and ingress of water are not permitted!

Function

The RWF40... provides the following functions:

- One **digital PID controller** with a 3-position or analog output (optional)
- To control 2-stage burners, the RWF40... can be switched over to provide 2-position control
- Automatic **thermostat (or pressurestat) function** in low-fire operation
- One **shift controller** for weather-dependent setpoint shifting
- One **minimum limiter and one maximum limiter** for the boiler temperature or the boiler pressure
- One **limit thermostat** to DIN EN 14597 (output 1)
- One potential-free **configurable** contact
- Manual operating mode
- Communication via serial port (option)
- Self-setting function

Block structure

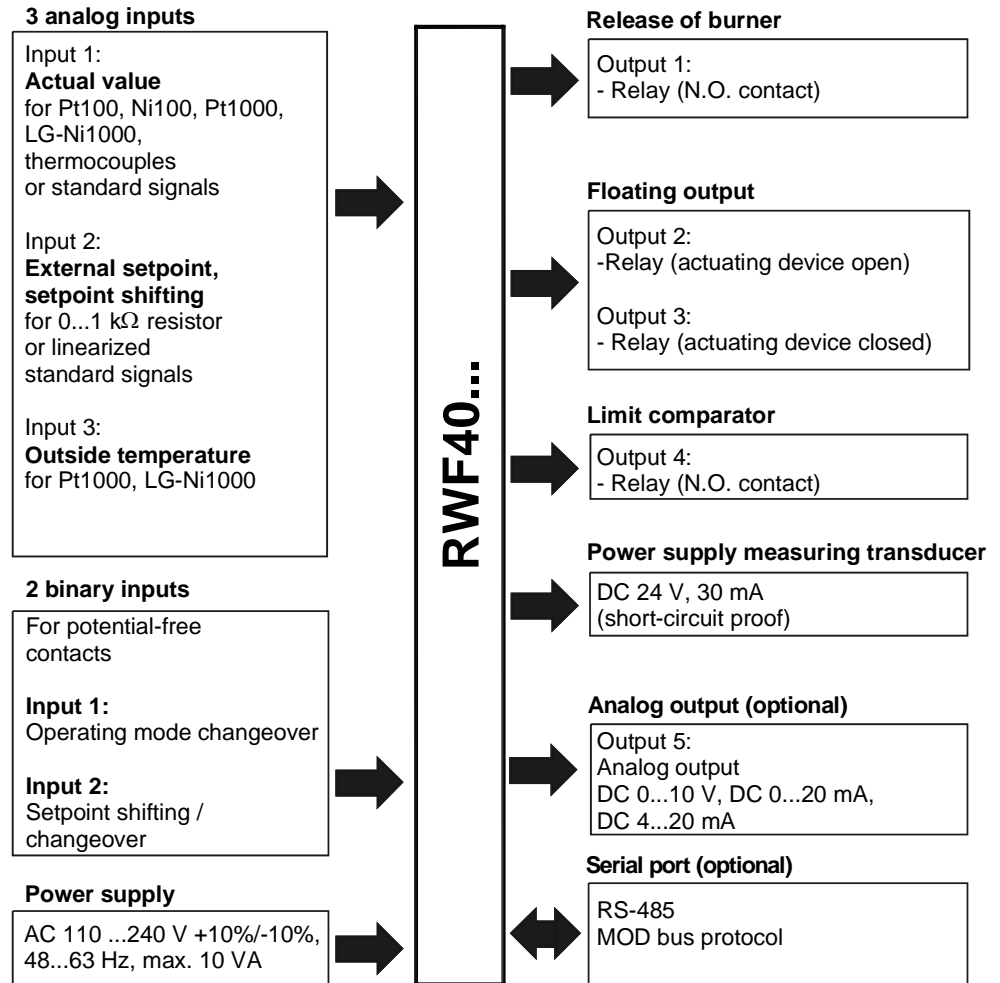

Function of the controller when used for burner control

Low-fire operation	In low-fire operation, the RWF40... operates like a control thermostat or pressurestat. This means that it operates as a 2-position controller maintaining the required setpoint by switching the burner on and off. The switching differential for 2-position operation can be adjusted within a wide range. If the demand for heat increases, the controller switches to nominal load operation only when an adjustable limit is exceeded. This function is aimed at optimizing the burner's switching ratio.
Nominal load operation, 2-stage control	In that case, the RWF40... operates as a 2-position controller with adjustable switching thresholds. Using the relays of the 3-position output, the RWF40... drives the actuator to the 1 st and 2 nd output stage. In this operating mode, the optional analog output switches between the minimum signal for the 1 st stage and the maximum output signal for the 2 nd stage.
Nominal load operation, modulating control	In that case, the RWF40... operates as a PID / PI controller with a 3-position output without position feedback signals or, optionally, with a modulating output. By making use of its self-setting facility, the RWF40... is able to determine the PID / PI control parameters, or the parameters can be set manually.
Binary input 1 (change-over of operating mode)	Using a potential-free contact, the RWF40... can be switched from the modulating mode to 2-stage operation.
Binary input 2 (setpoint shifting or setpoint changeover)	In the case «setpoint shifting» is configured, the current setpoint is shifted by an adjustable amount. Configuration of «setpoint changeover» provides changeover between 2 setpoints adjusted on the RWF40... If analog input 2 is configured for an «external setpoint», changeover is provided between the setpoint adjusted on the RWF40... and an external setpoint.
Limit comparator	Potential-free contact «K6» can be assigned a number of functions. <u>Example:</u> Limit value supervision
Operation	4 buttons on the unit front are used to operate and program the RWF40... During operation and programming, the 7-segment displays show the parameter values and parameter names.
Weather-dependent setpoint shifting	The controller's standard configuration ex works is such that when connecting a QAC22... outside sensor, automatic changeover to weather-dependent setpoint shifting takes place.



The signal delivered by the QAC2... outside sensor must not be fed parallel to several RWF40...!

Function of the controller when used for burner control (cont'd)

Analog input 1 (actual value sensor)

To acquire the actual value, a number of sensors can be connected to the RWF40...

		Measurement range
2-or 3-wire resistance sensors	Pt100 / IEC 751	-200...+850°C (-328...+1562°F)
	Pt1000 / IEC 751	-200...+850°C (-328...+1562°F)
	Ni100 / DIN 43760	-60...+230°C (-76...+482°F)
	Ni1000 / DIN 43760	-60...+230°C (-76...+482°F)
	LG-Ni1000	-50...+160°C (-58...+320°F)
Thermocouples	NiCr-Ni / type «K»	-200...+1372°C (-328...+2502°F)
	Cu-Cu-Ni / type «T»	-200...+400°C (-328...+752°F)
	NiCroSil-NiSiI / type «N»	-100...+1300°C (-148...+2372°F)
	FeCuNi / type «J»	-200...+1000°C (-328...+1832°F)
	Pt-RhPt / type «S»	0...1768°C (-32...3214°F)
	Pt-RhPt / type «R»	0...1768°C (-32...3214°F)
	Pt-RhPt / type «B»	0...1820°C (32...3308°F)
Linearized standard signals	0...20 mA	scalable -1999...+9999
	4...20 mA	scalable -1999...+9999
	DC 0...10 V	scalable -1999...+9999
	DC 0...1 V	scalable -1999...+9999

The power provided for the measuring transducers is DC 24 V / 30 mA.

Analog input 2 (external setpoint shift or external setpoint)

Feeding a signal to analog input 2, the controller's setpoint can be influenced. The influence can be scaled.

The input can be used as a feedback input of actuator position alternatively, and this feedback of position can be readout via RS485 interface (only RWF40.0x2B97)

The following signals can be used:

- Input signals DC 0...1 V, DC 0...10 V, 0...20 mA, 4...20 mA
- 1 kΩ potentiometer in a 2-wire circuit

Connection diagram (basic diagram)

Temperature and pressure control on a dual-fuel burner.
 Burner control and supervision are provided by burner control type LAL... or LFL...

Note

DC 24 V at terminals «G+» and «G-» is used for powering the QBE... pressure sensor!

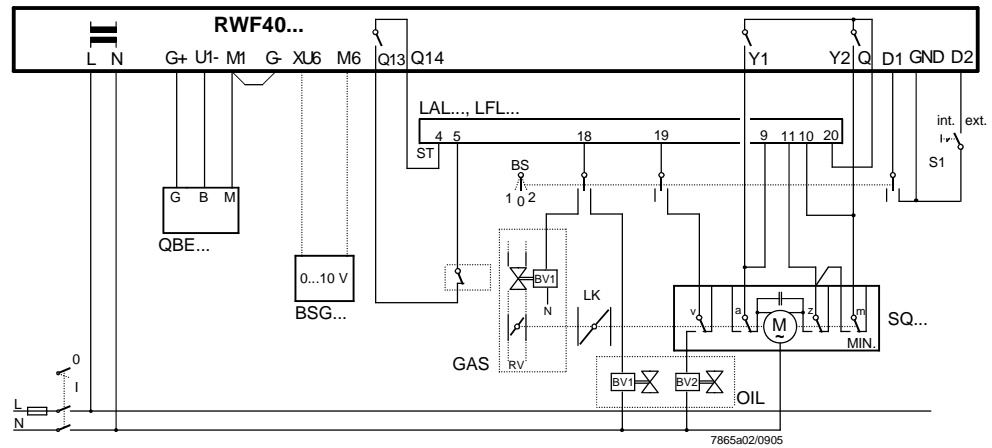
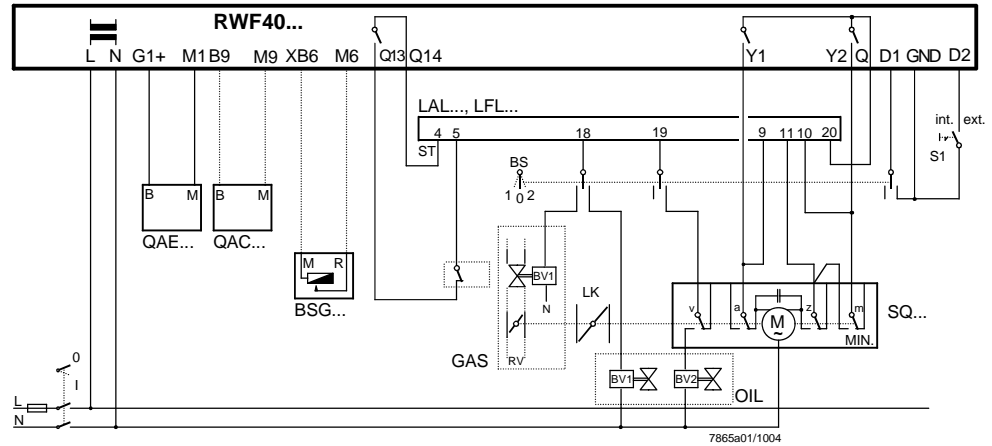

Legend

a	Limit switch for air damper position OPEN	QAE...	Immersion temperature sensor
BS	Operation selector 1 = firing on gas (modulating burner control) 2 = firing on oil (2-stage burner control)	QBE...	Pressure sensor
BV...	Fuel valve	RV	Gas control damper
BSG...	Remote setpoint adjuster (active when «S1» is closed)	S1	Internal / external setpoint switch (E)
L...	Burner control	SQ...	Actuator of burner's air damper and gas control damper
LK	Burner's air damper	ST	Connections for burner control's start control loop
m (MIN)	Auxiliary switch for controlling low-fire operation	v	Auxiliary switch for the release of the 2 nd fuel valve depending on the air damper position
QAC...	Outside sensor for weather-dependent setpoint shifting	z	End switch for the fully CLOSED position of the air damper

Dimensions

Dimensions in mm

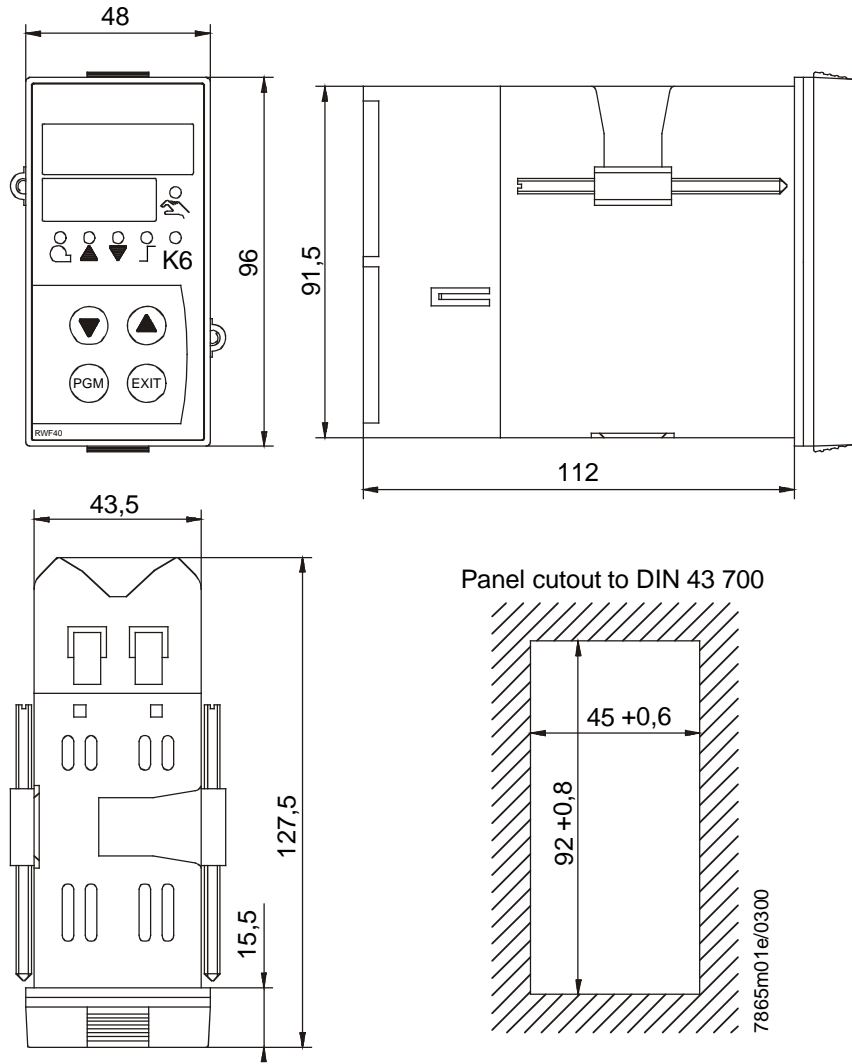

ARG40 adapter frame

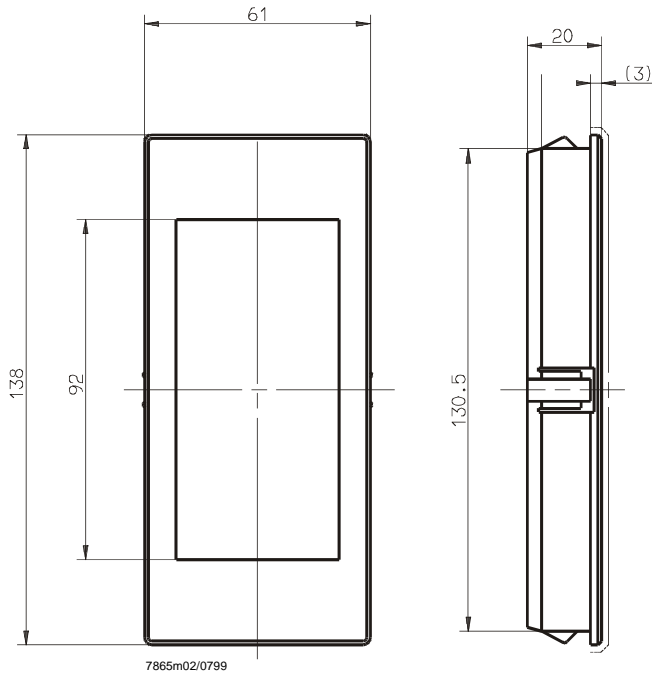

Dimensions (cont'd)

Dimensions in mm

ARG41

